

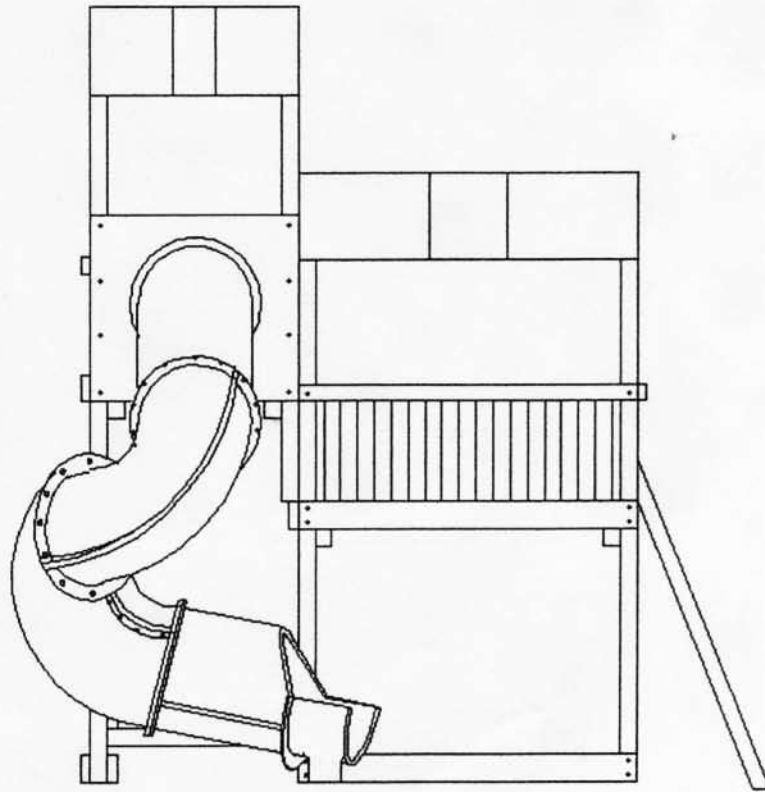

# SUPER SLIDE





# SUPER SLIDE

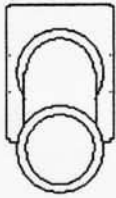

FACE PLATE  
ENTRY PIECE

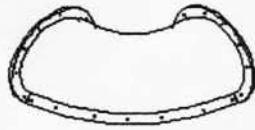

SLIDE SECTION



EXIT PIECE



FOOT STAND PIECE

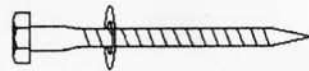

3 1/2" LAG SCREW W/ WASHER



1-1/4" BOLT W/ WASHERS AND NUT



3/4" BOLT W/ WASHER

# SUPER SLIDE

STEP 1 -TAKE THE ENTRANCE TUBE LABELED # 1 AND PLACE THE FACE PLATE ENTRY PIECE FLUSH TO THE BACK POSTS, SO THAT THE ENTRY WAY OF THE SLIDE IS FLUSH WITH THE DECK. FASTEN THE FACE PLATE ENTRY PIECE TO THE BACK POSTS WITH 3 1/2" LAG SCREW W/ 3/8" WASHERS IN EACH OF THE HOLES PROVIDED ON THE FACE PLATE ENTRY PIECE.

**NOTE: DO NOT THIGHTEN UNTIL ALL BOLTS, NUTS AND WASHERS ARE IN PLACE**

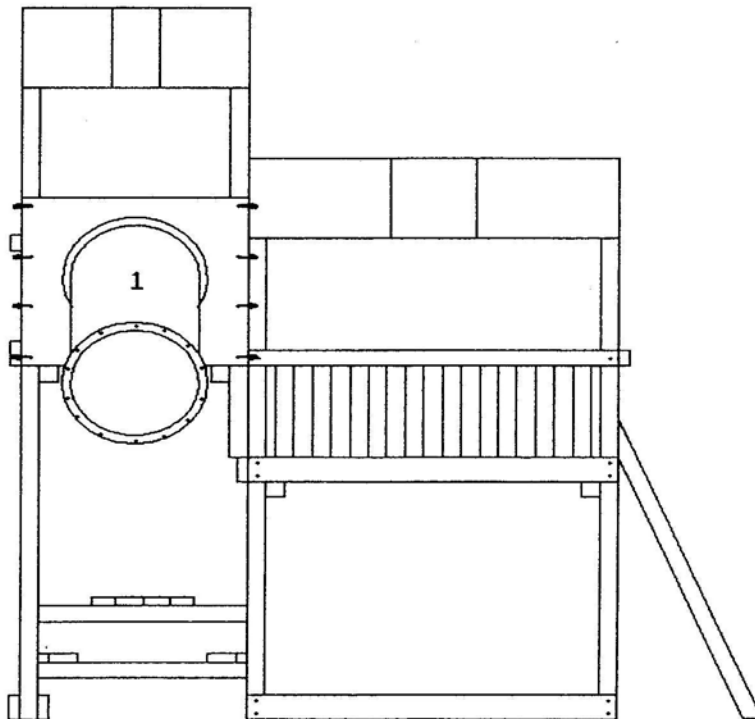

STEP 2 - LOCATE A TOP SLIDE SECTION(LABELED #2 WITH A OVERLAPPING FLANGE) AND BOTTOM SLIDE SECTION (LABELED #3 WITHOUT OVERLAPPING FLANGE), FASTEN THE TOP AND BOTTOM PIECES TOGETHER ALONG THE RIBS ON THE SLIDE SECTIONS WITH THE 3/8" X 1 1/4" LONG BOLTS AND NUTS PROVIDED, USING A WASHER ON BOTH SIDES OF THE FLANGE. MAKE SURE TO FASTEN THE NUTS AND BOLTS IN EACH HOLE PROVIDED ON THE RIBS, ON BOTH SIDES OF THE TOP AND BOTTOM SLIDE SECTIONS.

**NOTE: DO NOT THIGHTEN UNTIL ALL BOLTS, NUTS AND WASHERS ARE IN PLACE**

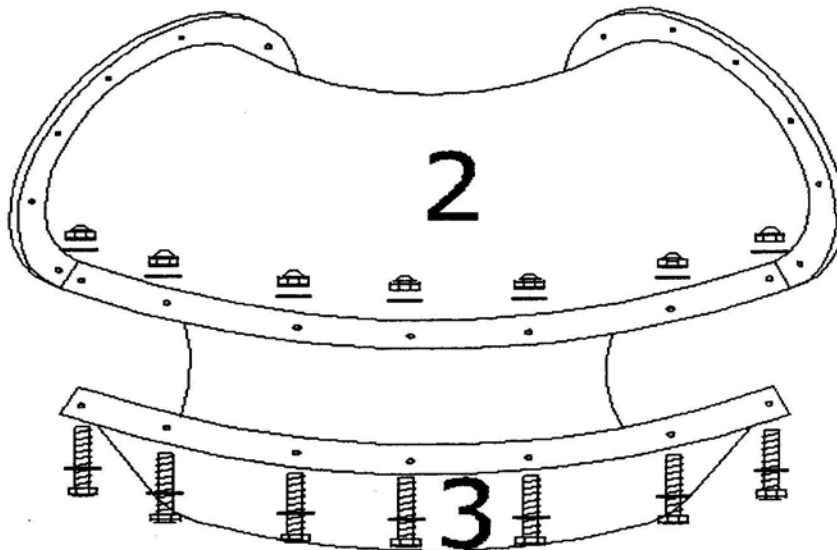

STEP 3 - NOW THAT THE FIRST CURVED SECTION IS ASSEMBLED, RAISE THE PIECE UP TO THE FACE PLATE ENTRY PIECE AND ROTATE THE OUTER RIBBED EDGE 2 HOLE POSITIONS TO THE RIGHT FROM TOP CENTER( THIS AREA IS RECOGNIZED BY THE RIB ALONG THE FACE PLATE ENTRY PIECE). ALIGN THE HOLES IN EACH OF THE FLANGES OF THE FACE PLATE ENTRY PIECE AND THE FIRST SLIDE SECTION. FASTEN THE SLIDE SECTION TO THE FACE PLATE ENTRY PIECE WITH THE 3/8" X 1 1/4" LONG BOLTS AND NUTS PROVIDED (FASTEN A COUPLE OF NUTS AND BOLTS AT THE TOP AND BOTTOM FIRST, THEN PROCEED TO FASTEN THE REST OF THE NUTS AND BOLTS.) MAKE SURE TO FASTEN THE NUTS AND BOLTS IN EACH OF THE HOLES PROVIDED IN EACH OF THE FLANGES.

**NOTE: DO NOT THIGHTEN UNTIL ALL BOLTS, NUTS AND WASHERS ARE IN PLACE**

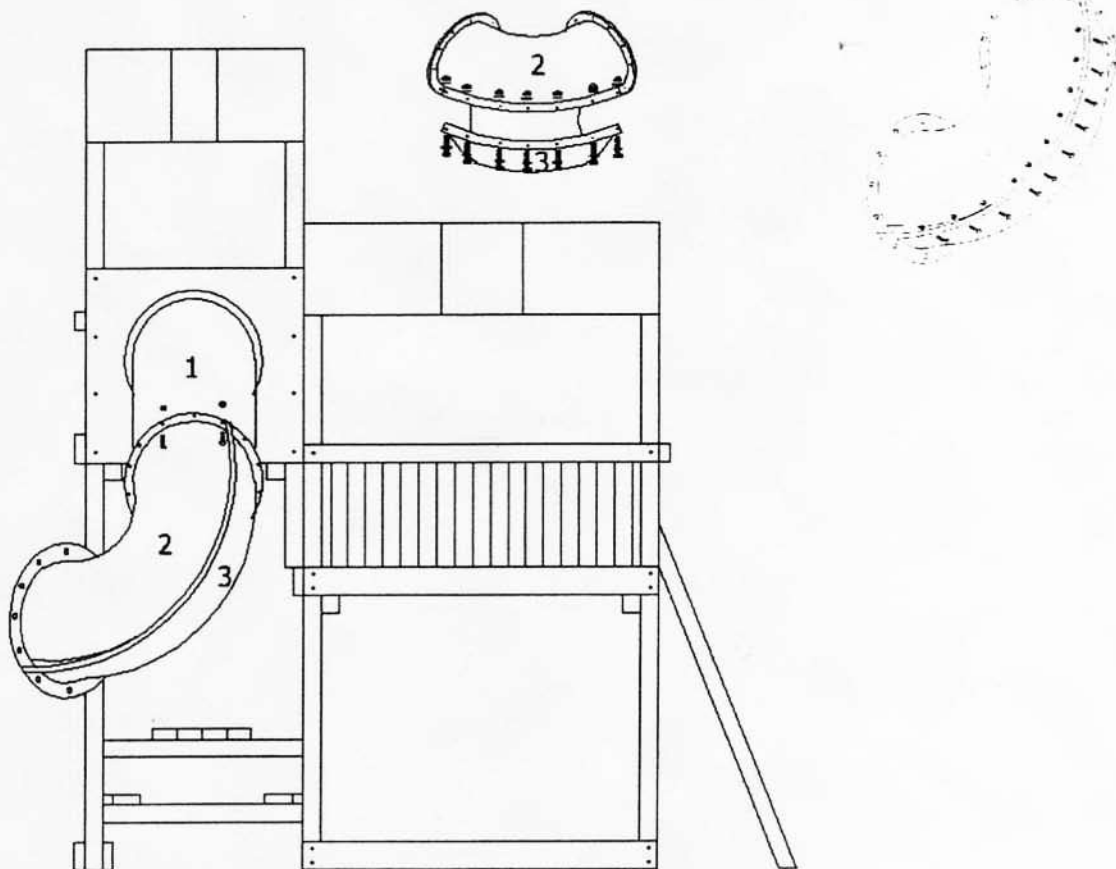

STEP 4 - LOCATE A TOP SLIDE SECTION (LABELED #2 WITH AN OVERLAPPING FLANGE) AND BOTTOM SLIDE SECTION (LABELED #3 WITHOUT OVERLAPPING FLANGE). FASTEN THE TOP AND BOTTOM PIECES TOGETHER ALONG THE RIBS ON THE SLIDE SECTIONS WITH THE 3/8" X 1 1/4" LONG BOLTS AND NUTS PROVIDED USING A WASHER ON BOTH SIDES OF THE FLANGE. MAKE SURE TO FASTEN THE NUTS AND BOLTS IN EACH HOLE PROVIDED ON THE RIBS, ON BOTH SIDES OF THE TOP AND BOTTOM SLIDE SECTIONS.

**NOTE: DO NOT THIGHTEN UNTIL ALL BOLTS, NUTS AND WASHERS ARE IN PLACE**

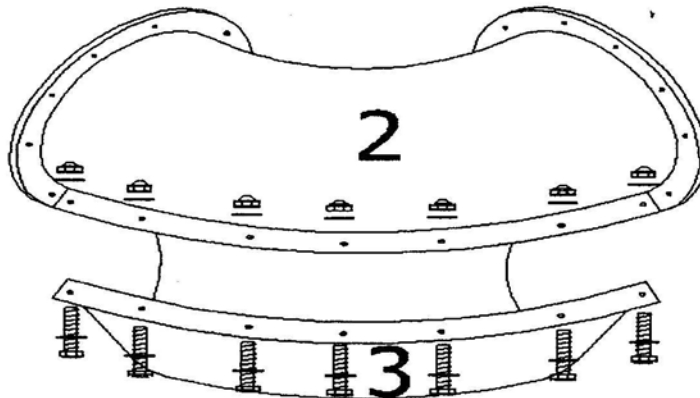

STEP 5 - NOW THAT THE SECOND CURVED SECTION IS ASSEMBLED, RAISE THE PIECE UP TO THE FIRST SLIDE SECTION PIECE AND ROTATE THE OUTER RIBBED EDGE TWO HOLE POSITIONS TO THE LEFT OF THE FIRST CURVED SECTION'S OUTER RIB. ALIGN THE HOLES IN EACH OF THE FLANGES OF THE FIRST CURVED SECTION AND THE SECOND CURVED SECTION. FASTEN THE SECOND CURVED SECTION TO THE FIRST CURVED SECTION WITH THE 3/8" X 1 1/4" LONG BOLTS AND NUTS PROVIDED, USING A WASHER ON BOTH SIDES OF THE FLANGE ( FASTEN A COUPLE OF NUTS AND BOLTS AT THE TOP AND BOTTOM FIRST, THEN PROCEED TO FASTEN THE REST OF THE NUTS AND BOLTS.) MAKE SURE TO FASTEN THE NUTS AND BOLTS IN EACH OF THE HOLES PROVIDED IN EACH OF THE FLANGES.

**NOTE: DO NOT THIGHTEN UNTIL ALL BOLTS, NUTS AND WASHERS ARE IN PLACE**

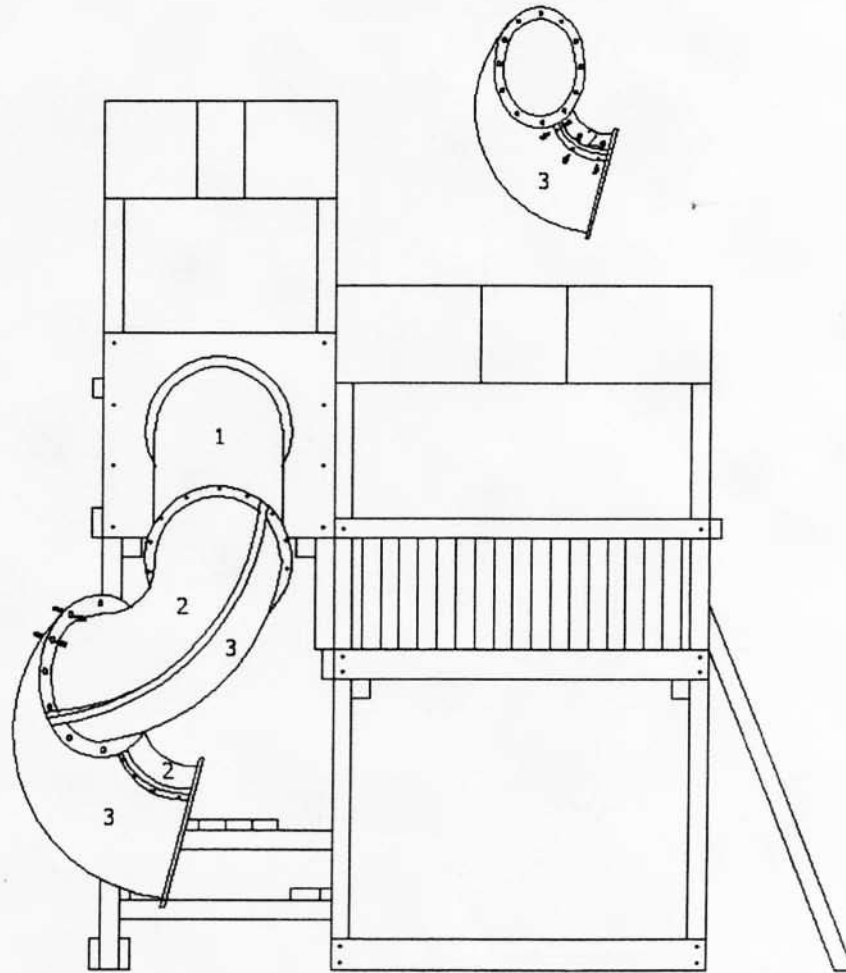

STEP 6 - LOCATE THE TOP (LABELED # 4 WITH LARGE CUTOUT SECTION) AND THE BOTTOM EXIT PIECE (LABELED #5 THIS IS THE ONLY CURVED SECTION REMAINING)) FASTEN THE EXIT PIECES ALONG THE RIBS WITH THE 3/8" X 1 1/4" LONG BOLTS AND NUTS PROVIDED USING A WASHER ON BOTH SIDES OF THE FLANGE. MAKE SURE TO FASTEN THE NUTS AND BOLTS IN EACH HOLE PROVIDED ON THE RIBS, ON BOTH SIDES OF THE TOP AND BOTTOM EXIT PIECES.

STEP 7 - LOCATE THE FOOT STAND PIECE. ROTATE THE FOOT STAND SECTION SO THAT THE ONLY HOLE ON THE TOP HALF OF THE CURVED SECTION IS ALIGNED WITH THE FIRST THREADED HOLE ON THE FOOT STAND SECTION. FASTEN THE FOOT STAND PIECE TO THE EXIT PIECE WITH THE 3/8" X 3/4" LONG BOLTS AND WASHERS PROVIDED. MAKE SURE TO FASTEN ALL 6 BOLTS IN EACH OF THE HOLES PROVIDED IN THE FOOT STAND PIECE.

STEP 8 - NOW THAT THE EXIT PIECE IS ASSEMBLED, RAISE THE EXIT PIECE UP TO THE SECOND CURVED SECTION AND ALIGN THE PILOT HOLES IN EACH OF THE FLANGES OF THE SECOND CURVED SECTION AND THE EXIT PIECE SO THAT THE FOOT REST SQUARELY ON THE GROUND. FASTEN THE EXIT PIECE TO THE SECOND CURVED SECTION WITH THE 3/8" X 1 1/4" BOLTS AND NUTS PROVIDED USING A WASHER ON EACH SIDE OF THE FLANGE( FASTEN A COUPLE OF NUTS AND BOLTS AT THE TOP AND BOTTOM FIRST, THEN PROCEED TO FASTEN THE REST OF THE NUTS AND BOLTS.) MAKE SURE TO FASTEN THE NUTS AND BOLTS IN EACH OF THE HOLES PROVIDED IN EACH OF THE FLANGES.

**NOTE: DO NOT THIGHTEN UNTIL ALL BOLTS, NUTS AND WASHERS ARE IN PLACE**

